

Electrical Characteristics	
Impedance	50 Ω
Frequency Range	0 ~ 8 GHz
V.S.W.R.	≤ 1.35 Max.(straight)

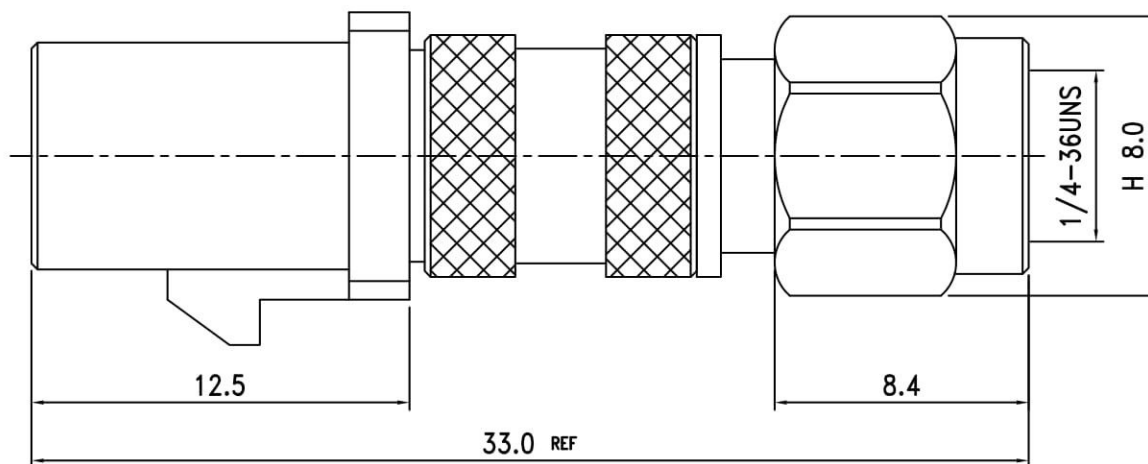
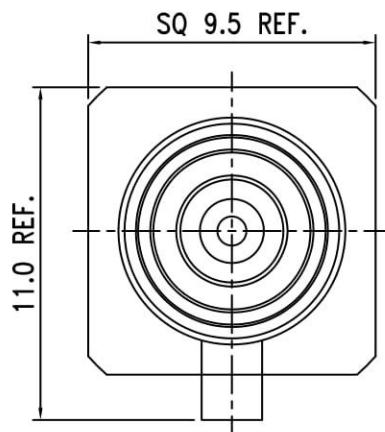

10.	Housing	PA66	1	Water Blue
9.	Shell	Brass	1	Nickel
8.	Gasket	Silicone	1	Red
7.	Retaining ring	Stainless Steel	1	None
6.	Insulation	PTFE	1	White
5.	Insulation	PTFE	1	White
4.	Pin	Phosphor Bronze	1	Gold
3.	Body	Brass	1	Nickel
2.	Body	Brass	1	Nickel
1.	Body	Brass	1	Nickel
NO.	DESCRIPTION	MATERIAL	Q' TY	FINISH

繪圖DRAWN	SCALE	UNITS	CFF.SM-AP-NEUP		
	比例 4:1	單位 mm			
審核CHECKED	公差TOLERANCE		圖名		
	.X	±0.2	TITLE		
主管APPROVAL	.XX	±0.1	版次REV.	電腦圖檔CAD FILE	日期DATE
	.XXX	±0.05	A		2016.06.13
	ANGLE	±0.5°			

  
 ROHS  
 COMPLIANT